

RYOBI

10 in. (254 mm)

TABLE SAW

MODEL NO. BTS15

REPAIR SHEET

FIGURE A

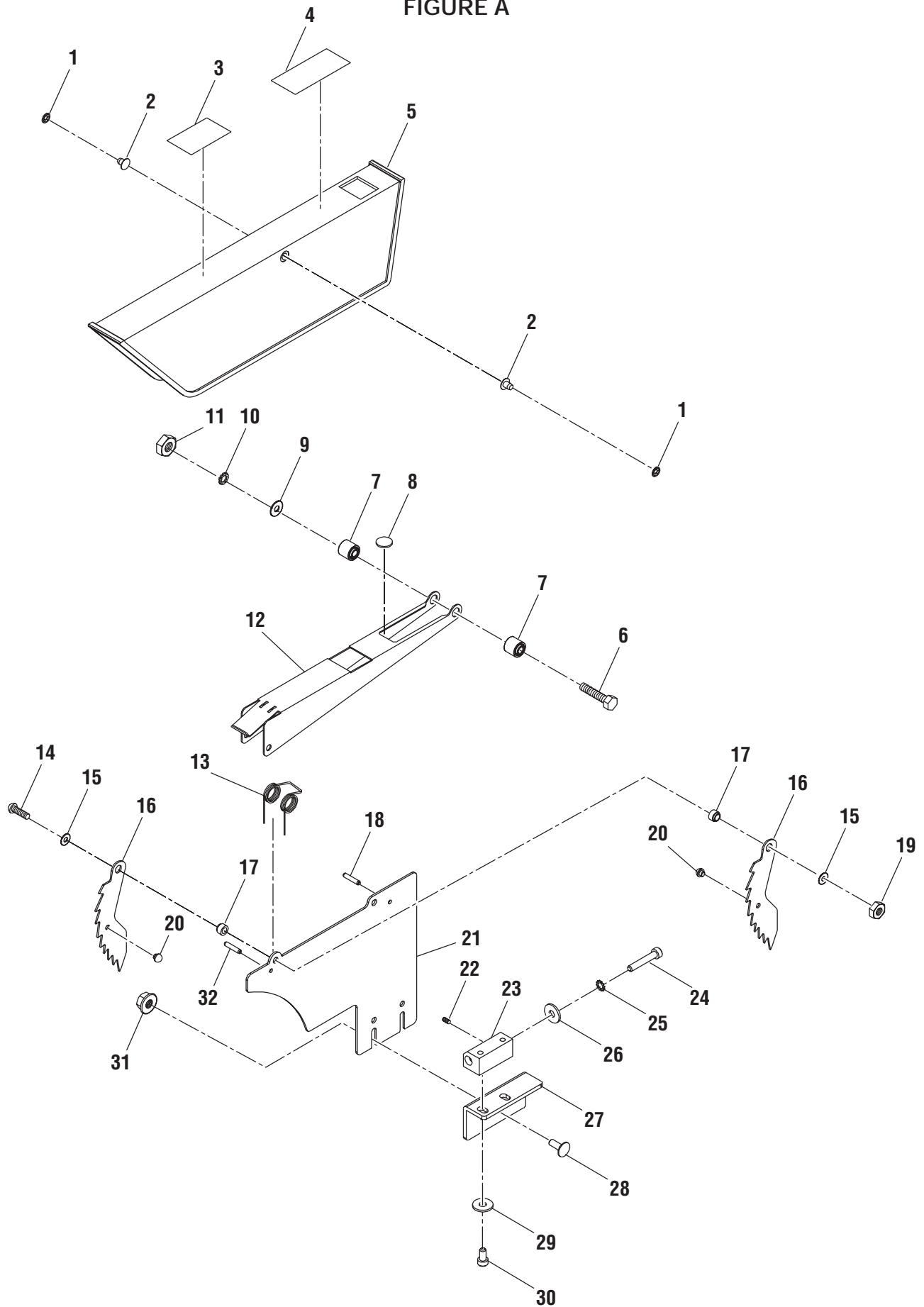

RYOBI 10 in. (254 mm) TABLE SAW – MODEL NUMBER BTS15

The model number will be found on a plate attached to the motor housing. Always mention the model number in all correspondence regarding your **TABLE SAW** or when ordering repair parts.

PARTS LIST FOR FIGURE A

Key No.	Part Number	Description	Qty.
1	A32503006000	PUSH NUT	2
2	A49510060080	RIVET (6 X 8)	2
3	608510000	HANDS-OFF LABEL	1
4	608509000	WARNING LABEL	1
5	608507000	BLADE GUARD	1
6	A01051141480	* HEX HEAD SCREW (1/4 in. X 1-1/2 in.)	1
7	609416000	SPACER A	2
8	608506000	CUSHION PAD	1
9	A35010651010	FLAT WASHER	1
10	A37110650000	STAR WASHER (6.5)	1
11	A30051014000	* HEX NUT (1/4 in.)	1
12	608511000	BRACKET	1
13	608513000	TORQUE SPRING	1
14	A08003060220	* PHILIPS SCREW (M6 X 22 mm)	1
15	A35030616080	FLAT WASHER	2
16	608504000	PAWL	2
17	608512000	SPACER (SMALL)	2
18	A42001040300	SPRING PIN (4 X 30 mm)	1
19	A30003006369	* HEX NUT (M6)	1
20	608505000	BLOCK	2
21	608501000	SPLITTER	1
22	A18003060080	* FIXING SCREW (M6 X 8 mm)	1
23	608503000	SPLITTER MOUNTING BLOCK	1
24	A07153141146	* HEX SOCKET SCREW (1/4 in. X 1-1/4 in.)	1
25	A37130611065	STAR WASHER (M6)	1
26	A35030610010	FLAT WASHER	1
27	608502000	MOUNTING BRACKET	1
28	608508000	* CARRIAGE SCREW (M6 X 18 mm)	2
29	A36030612157	LOCK WASHER (M6)	2
30	A07003060257	* HEX SOCKET SCREW (M6 X 25 mm)	2
31	A31503006000	* HEX WASHER NUT (M6)	2
32	A42001050220	SPRING PIN (5 X 22)	1
	608A04010	BLADE GUARD ASSEMBLY	

* Standard Hardware Item – May Be Purchased Locally

RYOBI 10 in. (254 mm) TABLE SAW – MODEL NUMBER BTS15

The model number will be found on a plate attached to the motor housing. Always mention the model number in all correspondence regarding your **TABLE SAW** or when ordering repair parts.

PARTS LIST FOR FIGURE B

Key No.	Part Number	Description	Qty.	Key No.	Part Number	Description	Qty.
1	588005100	BRUSH CAP	2	16	A46000150008	RETAINING RING (S-15)	1
2	588006100	CARBON BRUSH	2	17	608309000	OUTPUT GEAR	1
3	588007300	BRUSH HOLDER	2	18	A45204040120	KEY	1
4	A95001050060	* FIXING SCREW (M5 X 6 mm)	5	19	608301000	ARBOR	1
5	A18003050054	* FIXING SCREW (M5 X 5 mm)	2	20	A50060030040	BALL BEARING (6003)	1
6	A10003050250	* PHILLIP SCREW (M5 X 25 mm)	4	21	A63010000351	* O-RING (G35)	1
7	511304000	MOTOR HOUSING	1	22	608308000	SPACER	1
8	644307000	RUBBER BAR	1	23	608307000	BEARING HOLDER	1
9	9150A02000	FIELD ASSEMBLY	1	24	608306000	BEARING COVER	1
10	A90101050603	* SCREW (M5 X 60 mm)	2	25	A16000040250	* SCREW (M4 X 25 mm)	3
11	511312000	FAN CASING	1	26	608304000	INNER BLADE FLANGE	1
12	9053D01000	ARMATURE	1	27	608712000	BLADE	1
13	A63020000320	* O-RING (S32)	1	28	608305000	BLADE SPACER (SMALL)	1
14	608302000	GEAR BOX	1	29	608310000	OUTER BLADE FLANGE	1
15	A50006080049	* BALL BEARING (608)	1	30	608A03040	ARBOR ASSEMBLY	1

WARNING: Improper repair of a double insulated tool can result in damage to the double insulation system possibly causing electrical shock or electrocution. Any repairs requiring disassembly of your tool requires safety testing and should only be performed by a Ryobi Authorized Service Center. For the service center nearest you call 1-800-525-2579.

* Standard Hardware Item – May Be Purchased Locally

FIGURE C

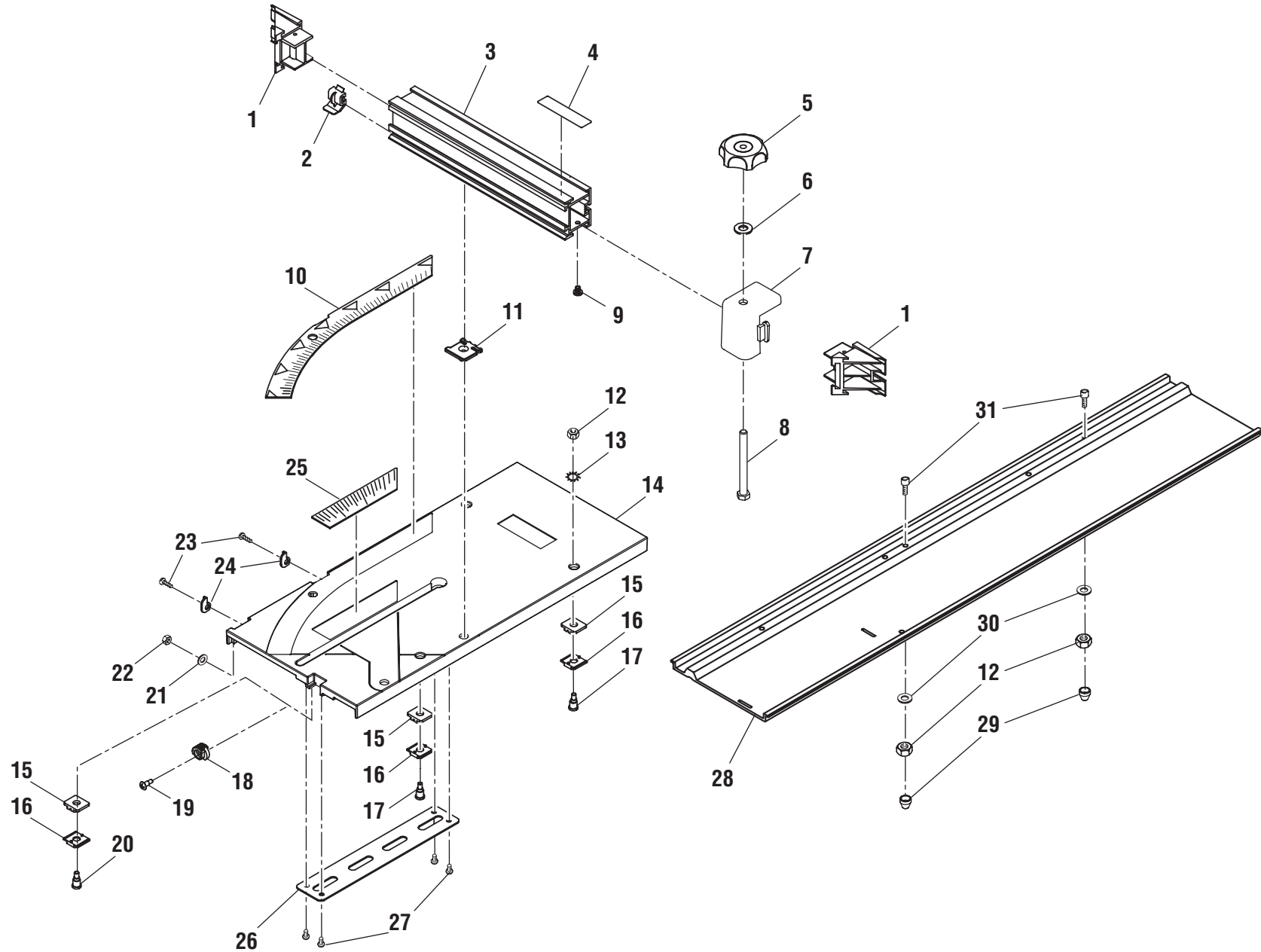

RYOBI 10 in. (254 mm) TABLE SAW – MODEL NUMBER BTS15

The model number will be found on a plate attached to the motor housing. Always mention the model number in all correspondence regarding your **TABLE SAW** or when ordering repair parts.

PARTS LIST FOR FIGURE C

Key No.	Part Number	Description	Qty.	Key No.	Part Number	Description	Qty.
1	608620000	END CAP	2	17	608423000	ECCENTRIC SCREW (M5)	3
2	608617000	MITER INDICATOR	1	18	608419000	LOCK KNOB	1
3	608618000	MITER FENCE	1	19	608409000	KNOB SCREW	1
4	608623000	MITER FENCE LABEL	1	20	608422000	* NON-ECCENTRIC SCREW (M5)	1
5	608621000	KNOB (5/16 in.)	1	21	A35030451010	FLAT WASHER	2
6	A35030816150	FLAT WASHER	1	22	A31753083200	LOCK NUT (#8-32)	2
7	644441000	MITER FENCE HOLDER	1	23	644435000	QUICK STOP SCREW (#8-32)	2
8	A01053560830	* HEX HEAD SCREW (5/16 in. X 83 mm)	1	24	644434000	QUICK STOP	2
9	A70003040080	* SELF-TAPPING SCREW (M4 X 8 mm)	2	25	608425000	MITER TABLE SCALE (SMALL)	1
10	608420000	MITER TABLE SCALE (LARGE)	1	26	608407000	HEDGE	1
11	608619000	PIVOT	1	27	A10003040063	* SCREW (M4 X 6 mm)	4
12	A31703005005	LOCK NUT (M5)	6	28	608405000	MITER TABLE BASE	1
13	A37130510060	* STAR WASHER (M5)	4	29	608427000	BUSHING	2
14	608406000	MITER TABLE	1	30	A36030508123	* SPRING WASHER (M5)	2
15	644429000	UPPER SLIDER	4	31	A07003050104	* HEX SOCKET SCREW (M5 X 10 mm)	2
16	644428000	LOWER SLIDER	4		608A05020	MITER FENCE ASSEMBLY	
					608A05030	SLIDING MITER TABLE ASSEMBLY	

* STANDARD HARDWARE ITEM – MAY BE PURCHASED LOCALLY

RYOBI 10 in. (254 mm) TABLE SAW – MODEL NUMBER BTS15

FIGURE D

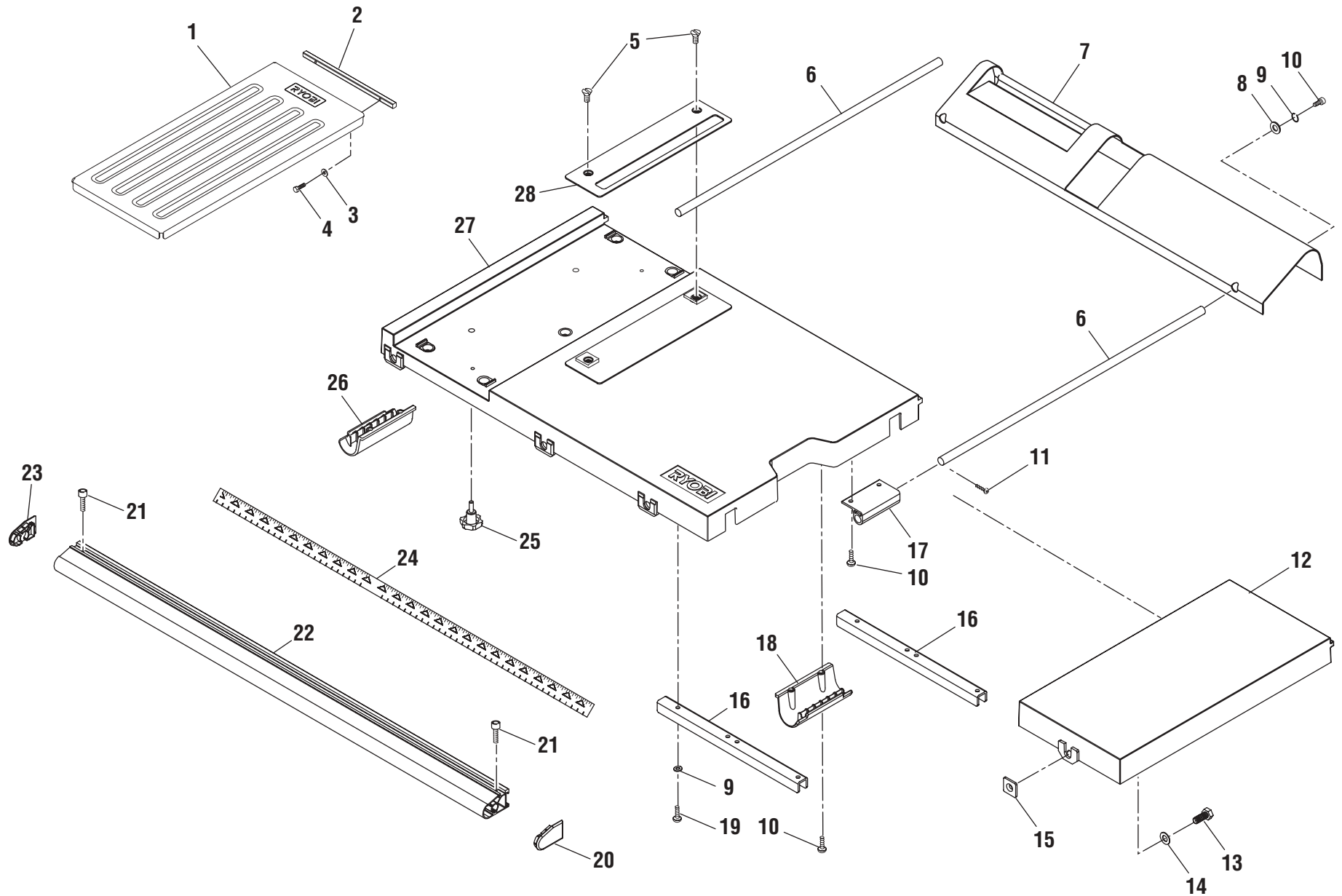

RYOBI 10 in. (254 mm) TABLE SAW – MODEL NUMBER BTS15

The model number will be found on a plate attached to the motor housing. Always mention the model number in all correspondence regarding your **TABLE SAW** or when ordering repair parts.

PARTS LIST FOR FIGURE D

Key No.	Part Number	Description	Qty.	Key No.	Part Number	Description	Qty.
1	608421000	PAN	1	15	644409000	MITER TABLE SCREW (5/16 in.)	3
2	608426000	REAR RAIL	1	16	608404000	CHANNEL	2
3	A35030401018	SPRING WASHER	2	17	608416000	EXTENSION SUPPORT	2
4	A01003040100	* HEX HEAD SCREW (M4 X 10 mm)	2	18	608415000	RIGHT HANDLE	1
5	A16003050100	* SCREW (M5 X 10 mm)	2	19	A07003060120	* HEX SOCKET SCREW (M6 X 12 mm)	8
6	608417000	OUTFEED ROD	2	20	608411000	RIGHT RAIL CAP	1
7	608418000	REAR OUTFEED	1	21	A07003030060	* HEX SOCKET SCREW (M3 X 6 mm)	2
8	A35030616105	FLAT WASHER	2	22	608408000	FRONT RAIL	1
9	A36030612157	* SPRING WASHER (M6)	10	23	608410000	LEFT RAIL CAP	1
10	A13003060120	* SCREW (M6 X 12 mm)	10	24	608414000	SCALE	1
11	A10003040050	* SCREW (M4 X 5 mm)	2	25	608413000	KNOB (M6 X 42 mm)	2
12	608403000	EXTENSION TABLE	1	26	608412000	LEFT HANDLE	1
13	A01053560150	* HEX HEAD SCREW (5/16 in. X 15 mm)	3	27	608401000	MAIN TABLE	1
14	A35030818152	FLAT WASHER	3	28	608402000	TABLE INSERT	1

* Standard Hardware Item – May Be Purchased Locally

FIGURE E

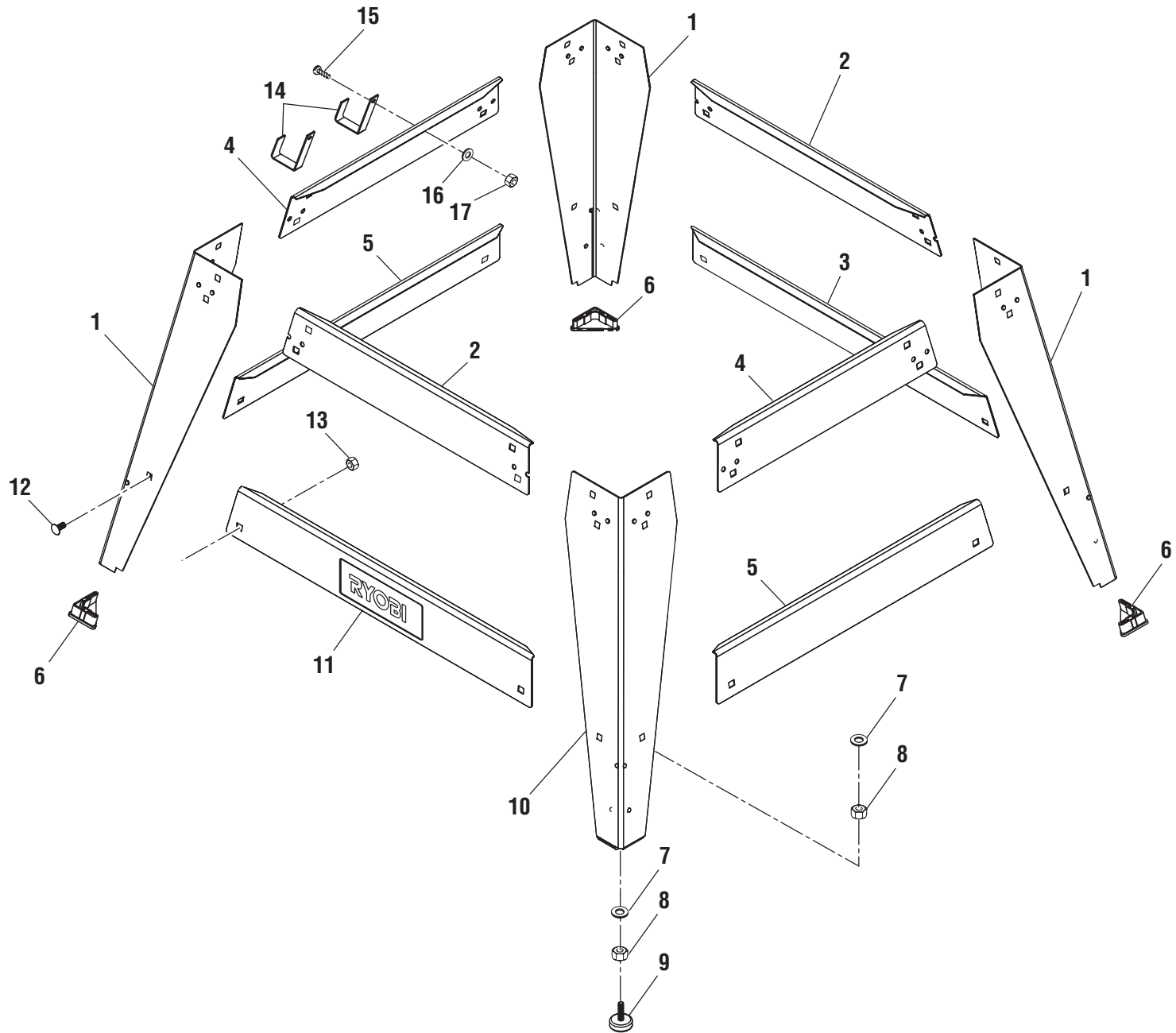

RYOBI 10 in. (254 mm) TABLE SAW – MODEL NUMBER BTS15

The model number will be found on a plate attached to the motor housing. Always mention the model number in all correspondence regarding your **TABLE SAW** or when ordering repair parts.

PARTS LIST FOR FIGURE E

Key No.	Part Number	Description	Qty.
1	608701000	TABLE LEG	3
2	608703000	UPPER TABLE BRACE (LONG)	2
3	608706000	LOWER TABLE BRACE (LONG)	1
4	608704000	UPPER TABLE BRACE (SHORT)	2
5	608707000	LOWER TABLE BRACE (SHORT)	2
6	608709000	L-SHAPED FOOT PAD	3
7	A35018518150	FLAT WASHER	2
8	A30051056000	* HEX NUT (5/16 in.)	2
9	644706000	FOOT PAD	1
10	608702000	TABLE LEG	1
11	608705000	LOWER TABLE BRACE	1
12	608710000	* CARRIAGE SCREW (5/16 in. X 3/4 in.)	24
13	A31553056000	* HEX WASHER HEAD SCREW NUT (5/16 in.)	24
14	608708000	HANGER	2
15	A13053140486	* SCREW (1/4 in. X 1/2 in.)	2
16	A35030651301	FLAT WASHER	2
17	A30053014008	* HEX NUT (1/4 in. X 20)	2

* Standard Hardware Item – May Be Purchased Locally

RYOBI 10 in. (254 mm) TABLE SAW – MODEL NUMBER BTS15

FIGURE F

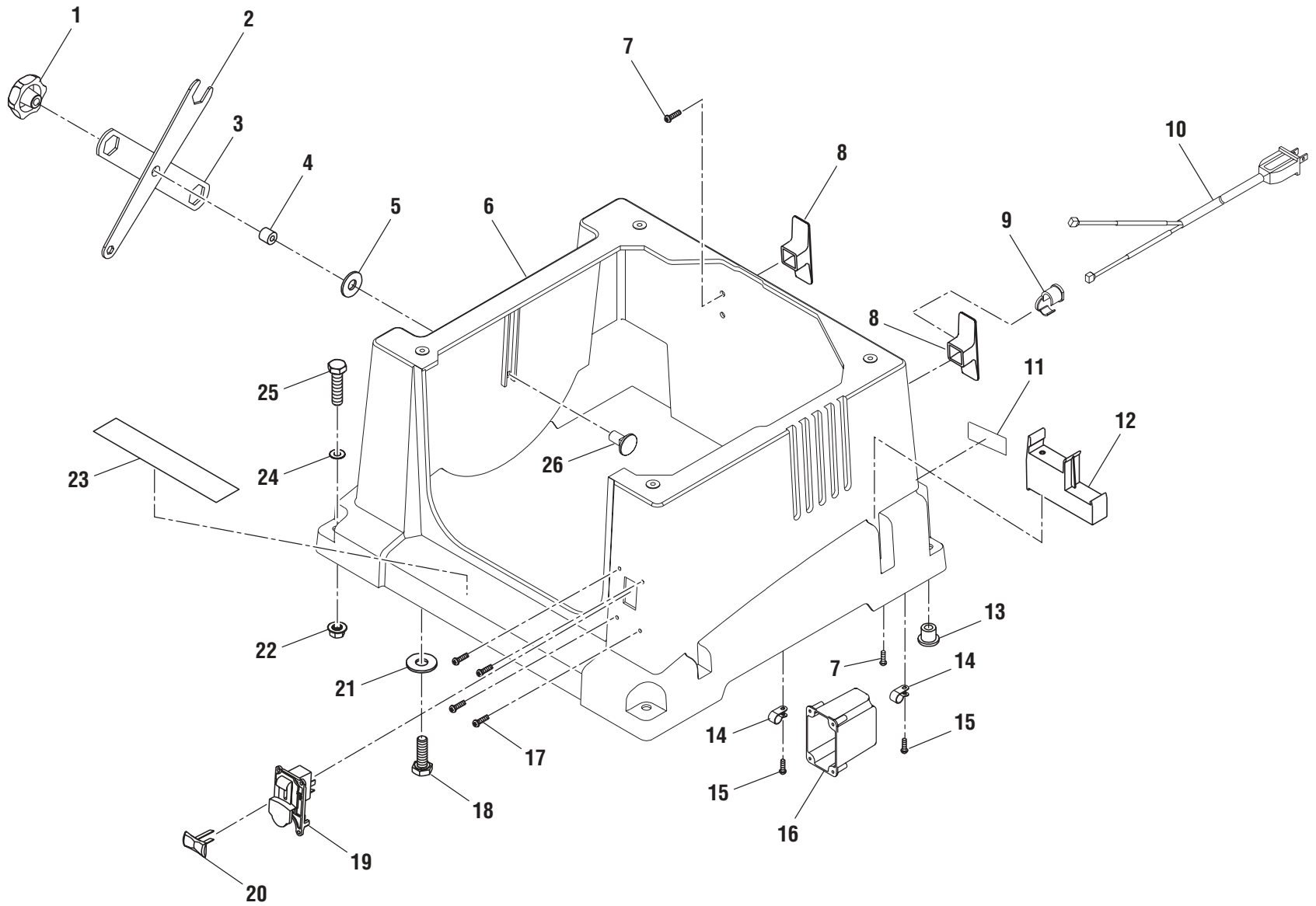

RYOBI 10 in. (254 mm) TABLE SAW – MODEL NUMBER BTS15

The model number will be found on a plate attached to the motor housing. Always mention the model number in all correspondence regarding your **TABLE SAW** or when ordering repair parts.

PARTS LIST FOR FIGURE F

Key No.	Part Number	Description	Qty.
1	608109000	KNOB	1
2	608121000	WRENCH	1
3	608122000	WRENCH	1
4	608120000	BLADE STORAGE BUSHING	1
5	A35031152620	FLAT WASHER	1
6	608101000	BASE	1
7	A71003040150	* TAPPING SCREW (M4 X 15 mm)	6
8	608106000	CORD STORAGE CLEATS	2
9	E07050613002	STRAIN RELIEF	1
10	609114000	POWER CORD	2
11	608303000	MOTOR LABEL	1
12	608105000	EXTENSION TABLE HANGER	2
13	608104000	BASE FOOT PAD	4
14	E07000846157	CORD CLAMP	2
15	A70003040100	* SELF-TAPPING SCREW (M4 X 10 mm)	2
16	608103000	SWITCH BOX	1
17	A70003040180	* TAPPING SCREW (M4 X 18 mm)	4
18	A01001060200	* HEX WASHER HEAD SCREW (M6 X 20 mm)	4
19	608108000	SWITCH ASSEMBLY	1
20	628305000	SWITCH KEY	2
21	A35010616105	FLAT WASHER	4
22	A31553056000	* HEX WASHER HEAD SCREW NUT (5/16 in.)	4
23	608125000	CABINET WARNING LABEL	1
24	A35038518150	FLAT WASHER	4
25	A01053560020	* HEX HEAD SCREW (5/16 in. X 2 in.)	4
26	608119000	* CARRIAGE SCREW (5/16 in. X 1-1/2 in.)	1

* Standard Hardware Item – May Be Purchased Locally

FIGURE G

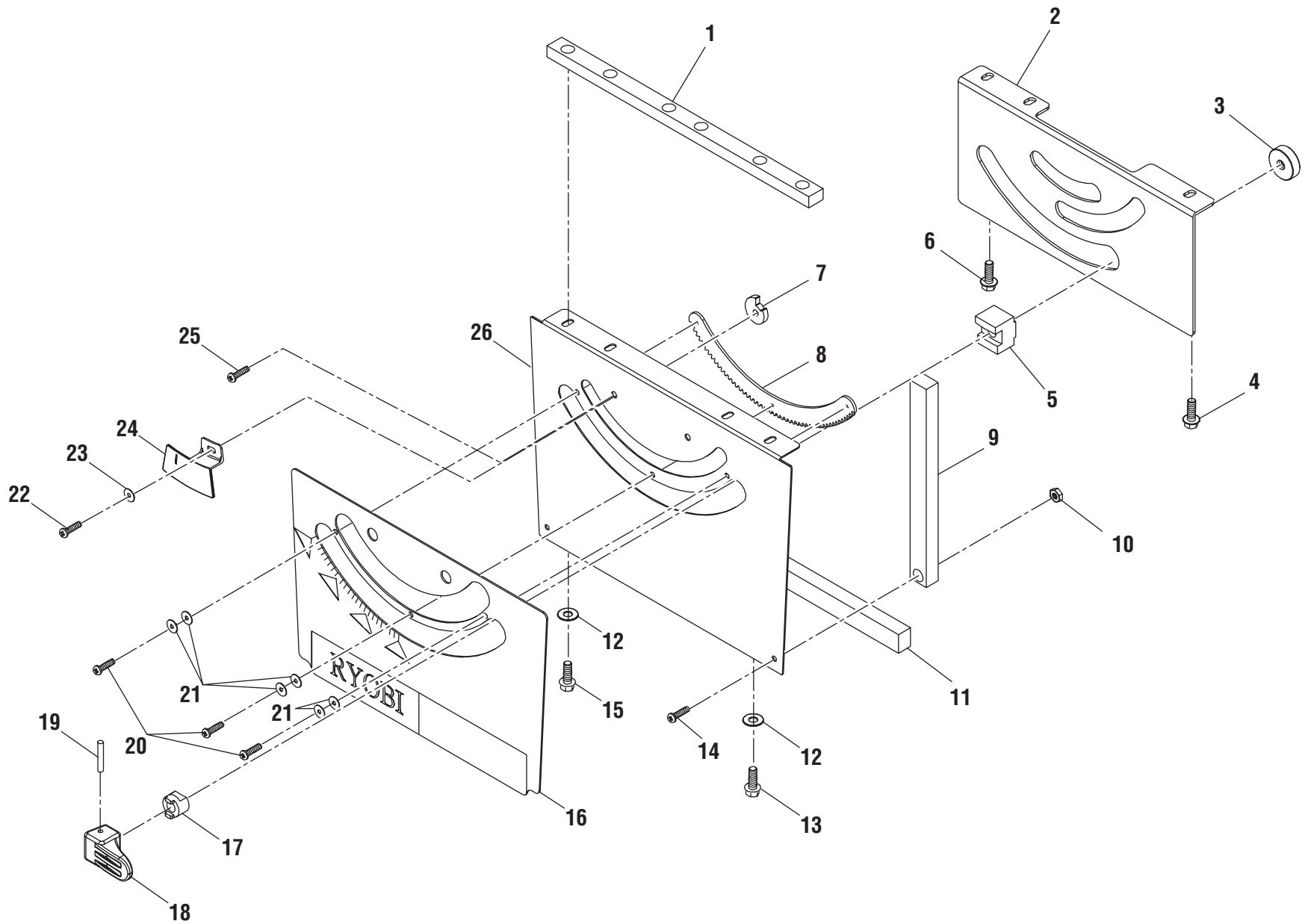

RYOBI 10 in. (254 mm) TABLE SAW – MODEL NUMBER BTS15

The model number will be found on a plate attached to the motor housing. Always mention the model number in all correspondence regarding your **TABLE SAW** or when ordering repair parts.

PARTS LIST FOR FIGURE G

Key No.	Part Number	Description	Qty.
1	608117000	DUST FOAM	1
2	608112000	PANEL SUPPORT	1
3	608124000	WASHER	1
4	A09001060150	* HEX HEAD BOLT (M6 X 15 mm)	2
5	608113000	BLOCK	1
6	A09001060100	* HEX WASHER HEAD SCREW (M6 X 10 mm)	1
7	609125000	ANGLING PAD	2
8	608110000	SUPPORT RACK	1
9	609106000	DUST FOAM	2
10	A31703005005	LOCK NUT	2
11	608118000	DUST FOAM	1
12	A35030613010	FLAT WASHER	4
13	A07003060150	* HEX SOCKET SCREW (M6 X 15 mm)	3
14	A10003050100	* SCREW (M5 X 10 mm)	2
15	A07003060100	* HEX SOCKET SCREW (M6 X 10 mm)	1
16	608116000	FRONT PANEL STICKER	1
17	608111000	BEVEL LOCKER PAD	1
18	608114000	BEVEL LOCKER	1
19	A42001040280	SPRING PIN (4 X 28 mm)	1
20	A10003040066	* SCREW (M4 X 6 mm)	3
21	608123000	WEAR DISC	6
22	A10003040107	* SCREW (M4 X 10 mm)	1
23	A35030410018	FLAT WASHER	1
24	608115000	BEVEL INDICATOR	1
25	A08003060106	* HEX SOCKET SCREW (M6 X 10 mm)	2
26	608107000	FRONT PANEL	1

* Standard Hardware Item – May Be Purchased Locally

FIGURE H

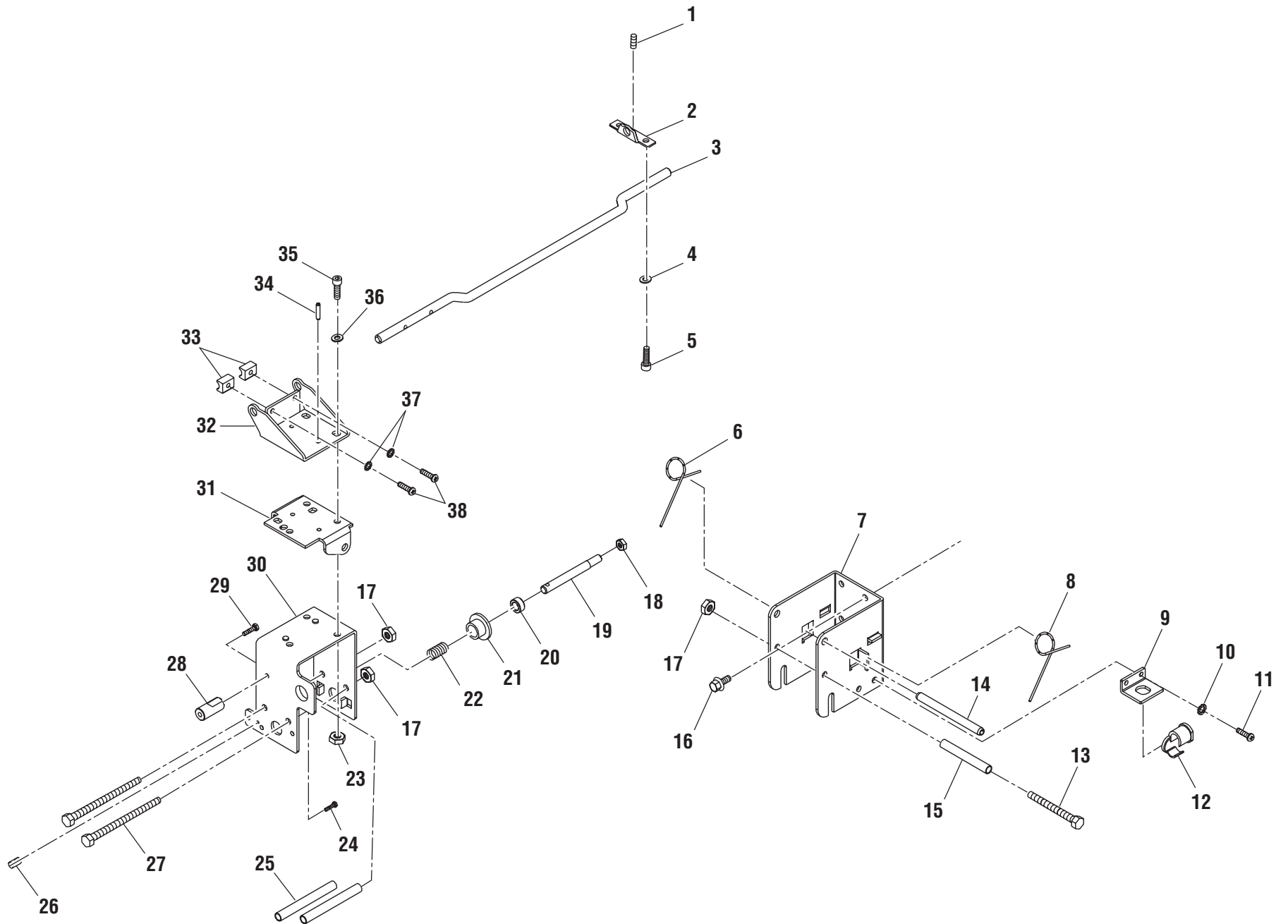

RYOBI 10 in. (254 mm) TABLE SAW – MODEL NUMBER BTS15

The model number will be found on a plate attached to the motor housing. Always mention the model number in all correspondence regarding your **TABLE SAW** or when ordering repair parts.

PARTS LIST FOR FIGURE H

Key No.	Part Number	Description	Qty.	Key No.	Part Number	Description	Qty.
1	A95001050060	* FIXING SCREW (M5 X 6 mm)	5	20	608214000	BEVEL LOCK SHAFT	1
2	608221000	ROCKING ROD BASE	3	21	608213000	BUSHING	1
3	608210000	ROCKING ROD	1	22	608215000	BEVEL LOCK SPRING	1
4	A36030612157	* SPRING WASHER (M6)	6	23	A31503006000	* HEX WASHER HEAD NUT (M6)	3
5	A07003060156	* HEX SOCKET SCREW (M6 X 15 mm)	6	24	A01003040130	* HEX HEAD BOLT (M4 X 13 mm)	1
6	608225000	DRIVER SPRING (L)	1	25	609208000	SPACER (9.5 X 84 mm)	2
7	608220000	RAISE BASE	1	26	608219000	INDICATOR SUPPORT	1
8	608224000	DRIVER SPRING (R)	1	27	A01003061000	* HEX HEAD BOLT (M6 X 100 mm)	2
9	608209000	STRAIN RELIEF BRACKET	1	28	608218000	BEVEL STOPPER (14 X 34 mm)	1
10	A36030508123	* SPRING WASHER (M5)	2	29	A01003050100	* HEX HEAD BOLT (M5 X 10 mm)	1
11	A10003050083	* SCREW (M5 X 8 mm)	2	30	608216000	BEVEL CASE	1
12	E07050613002	STRAIN RELIEF	1	31	608207000	RAISE SUPPORT	1
13	A01003060820	* HEX HEAD SCREW (M6 X 82 mm)	1	32	609203000	PIVOT BASE	1
14	A42001080900	SPRING PIN (8 X 90 mm)	1	33	609202000	BLOCK	2
15	609212000	SPACER (9.5 X 69 mm)	1	34	A42001040100	SPRING PIN (4 X 10 mm)	2
16	A09001060150	* HEX HEAD BOLT (M6 X 15 mm)	4	35	A07003060150	* HEX SOCKET SCREW (M6 X 15 mm)	3
17	A30003006003	* HEX NUT (M6)	3	36	A36030612157	* SPRING WASHER (M6)	3
18	A31703008000	LOCK NUT	1	37	A37130510060	* STAR WASHER (M5)	2
19	608212000	BEVEL LOCK PILLAR	1	38	A10003050180	* SCREW (M5 X 18 mm)	2

* Standard Hardware Item – May Be Purchased Locally

FIGURE I

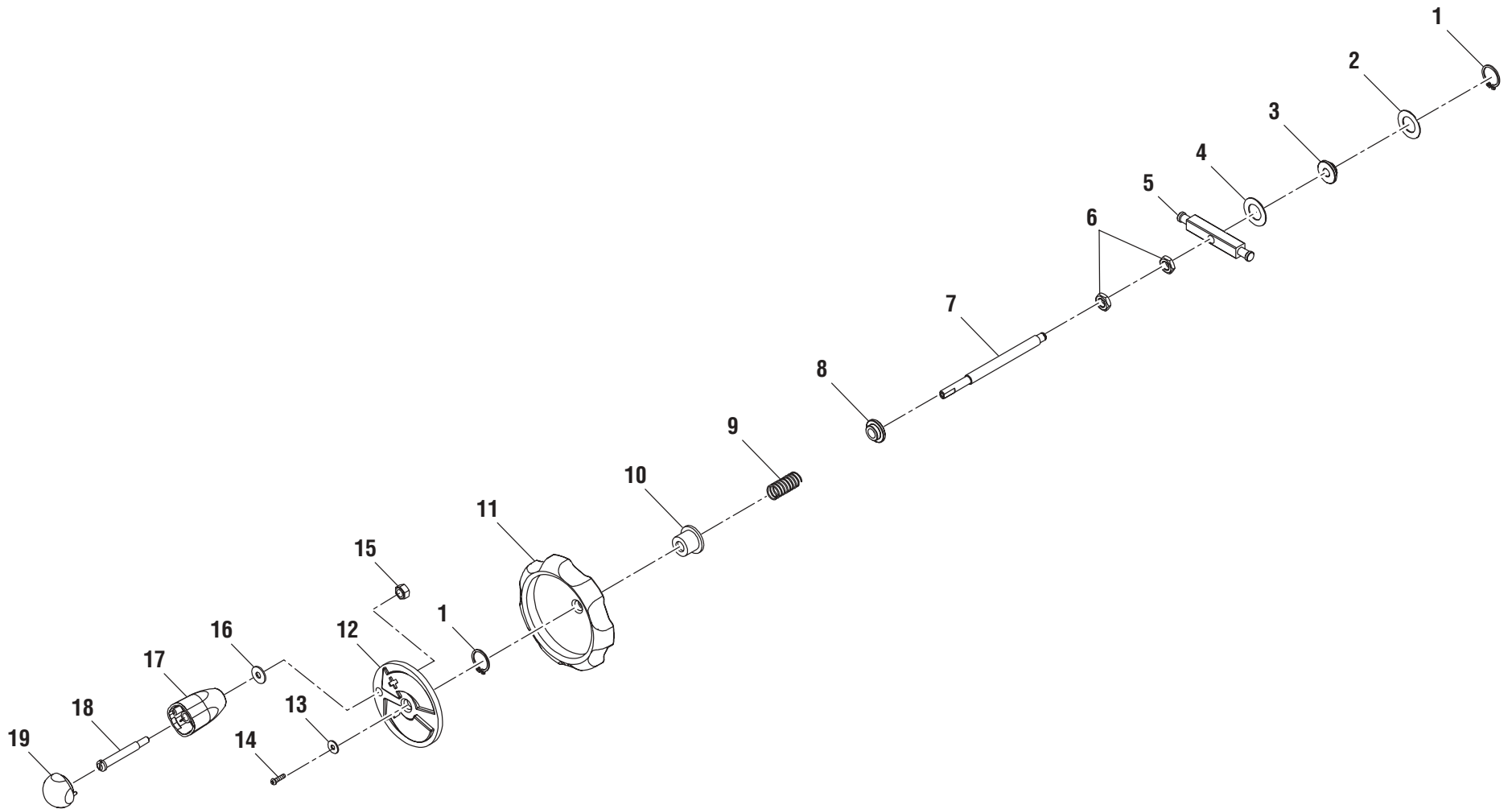

RYOBI 10 in. (254 mm) TABLE SAW – MODEL NUMBER BTS15

The model number will be found on a plate attached to the motor housing. Always mention the model number in all correspondence regarding your **TABLE SAW** or when ordering repair parts.

PARTS LIST FOR FIGURE I

Key No.	Part Number	Description	Qty.
1	A46000080005	C-RING	2
2	A35030818120	FLAT WASHER	1
3	609214000	REAR BUSHING	1
4	A35030816121	FLAT WASHER	1
5	608208000	DRIVER	1
6	A30003010000	* HEX NUT (M10 X 4T)	2
7	608206000	DRIVE BOLT (M10)	1
8	608222000	FRONT BUSHING	1
9	608211000	SPRING	1
10	608217000	SPRING COVER	1
11	608205000	MITER HAND WHEEL	1
12	608204000	HAND WHEEL	1
13	A35030410018	FLAT WASHER	1
14	A10003040106	* HEX SOCKET SCREW (M4 X 10 mm)	1
15	A31703006004	LOCK NUT (M6)	1
16	A35030616150	FLAT WASHER	1
17	608203000	HANDLE (SHORT)	1
18	608202000	* BOLT (M6 X 52 mm)	1
19	608201000	HANDLE CAP	1
	S60800100	HANDWHEEL ASSEMBLY	
	983000-290	OPERATOR'S MANUAL	
	983000-290R	REPAIR SHEET	
	2-13-04		

* Standard Hardware Item – May Be Purchased Locally

FIGURE J

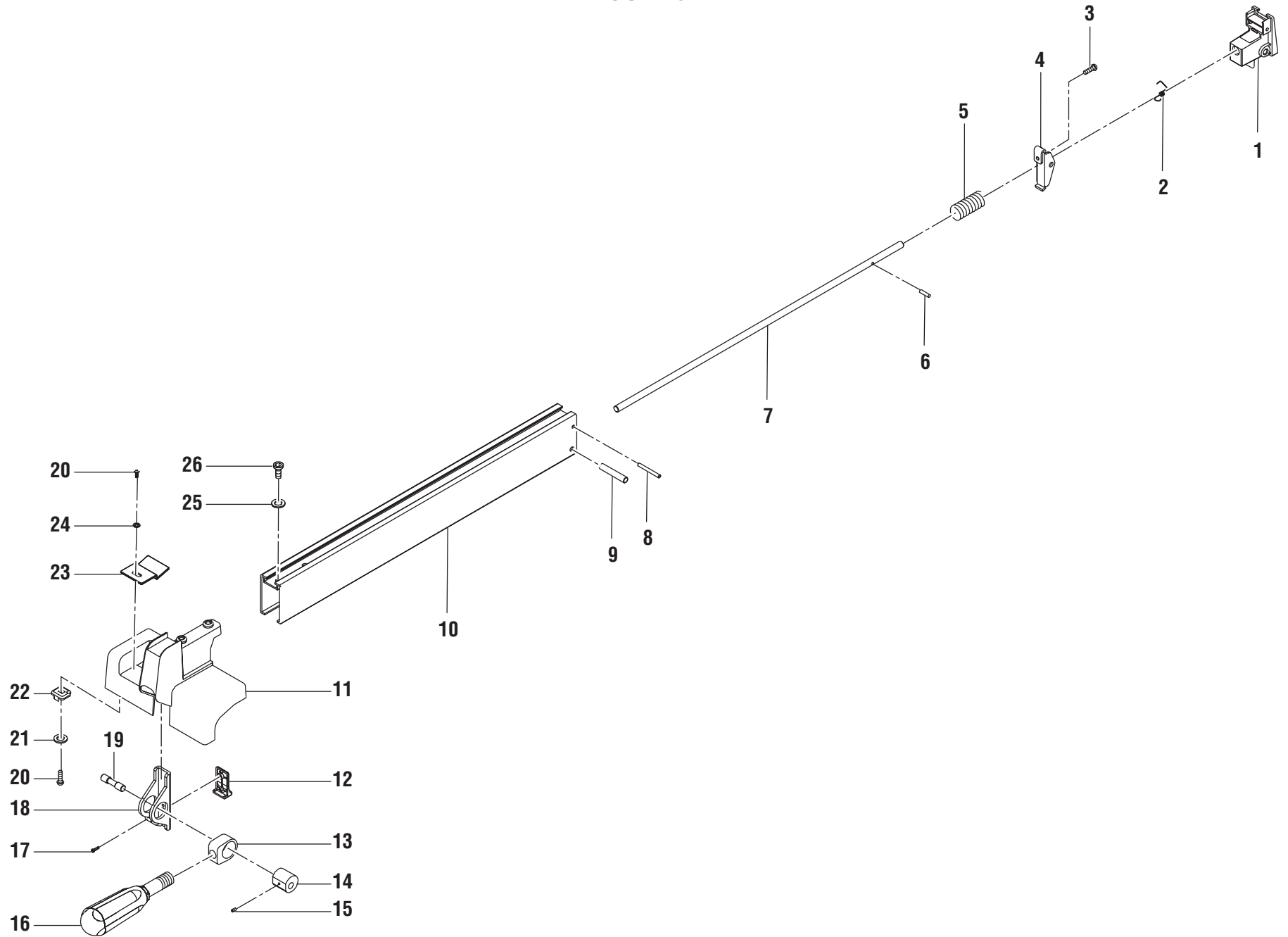

RYOBI 10 in. (254 mm) TABLE SAW – MODEL NUMBER BTS15

The model number will be found on a plate attached to the motor housing. Always mention the model number in all correspondence regarding your **TABLE SAW** or when ordering repair parts.

PARTS LIST FOR FIGURE J

Key No.	Part Number	Description	Qty.
1	608615000	REAR FENCE CAP	1
2	608622000	FIXING SPRING	1
3	A10003050256	* SCREW (M5 X 25 mm)	1
4	608614000	REAR CLAMP	1
5	608613000	COMPRESSION SPRING (17 X 45 mm)	1
6	A42001032200	SPRING PIN (3.2 X 20 mm)	1
7	608612000	ROD	1
8	608611000	PIN (4 X 33.5 mm)	1
9	608610000	CLAMP PIN (6 X 33.5 mm)	1
10	608609000	FENCE	1
11	608601000	FENCE BLOCK	1
12	608603000	FENCE CLAMP	1
13	608616000	* BUSHING (22 X 14.5 mm)	1
14	608604000	CAM (22 X 22 mm)	1
15	A18003040060	* SET SCREW (M4 X 6 mm)	1
16	608605000	HANDLE	1
17	A70003040060	* SELF-TAPPING SCREW (M4 X 6 mm)	1
18	608602000	CAM BRACKET	1
19	608606000	SHAFT	1
20	A10003040100	* SCREW (M4 X 10 mm)	3
21	A37130400000	STAR WASHER (M4)	2
22	608608000	PLASTIC PAD	2
23	608607000	FENCE INDICATOR	1
24	A35030410018	FLAT WASHER	1
25	A35036516010	FLAT WASHER	2
26	A04053140150	* HEX SOCKET SCREW (1/4 in. X 15 mm)	2
	608A05040	RIP FENCE ASSEMBLY	

* Standard Hardware Item – May Be Purchased Locally